

Microworks

a collection of five-second works
mostly involving a solo percussionist

Andrew S. Allen

Thoughts on Duration

Conceptual art can be an eager vessel for the "immediate." When I set out to write this collection of works, I started with the idea of making the pieces each no longer than five seconds. I began to consider what a musical engagement in this small space could mean and what sorts of directions my compositional style would be lead.

Consider the microchip; it works in much the same way as a collection of electrical components that are soldered together do (capacitors, resistors, transistors, etc.) except that it compacts all of those component functions into a singular, smaller unit; essentially a reduction of larger, more unyieldingly-complex schematics. Much in the same way as a microchip, I consider these compositions complete works by themselves, just smaller. Our adaptive facilities allow us to make great leaps in perceptual magnitudes. I've tried to reduce the footprint, not the content.

THESE WORKS WERE COMMISSIONED BY DUSTIN DONAHUE.

Collection List:

74C14

for six beer bottles and six brass mallets

Ah, yes

for mouth sounds

Anna, watching couple eating bagel together while he reads

The Speed of Trust* and she reads *The Sex Lives of Animals

for mixed axillary percussion

Arem

for a six pack of cheap beer

bangs anecdote

for solo bongo player and one bongo

(EXAMPLE OF BLURT):

MIKE -> NERD -> [BLURT] -> MIKE IS A NERD

for laptop operator

Crabbingoff Kingstreet

for wire-bound steel frame

while the dog meat's cookin'

for a hungry knife-wielding person,

3 red potatoes and a stalk of celery

(-*)

for your left and right eyelids

on going on a diet devoid of

high-fructose corn syrup and foxconn...

for a large pad of paper (multiple pages)

Gazebo, Gazelle, zilch.

for heterogeneous pitched instrument

Jew-Goldberg, the accountant,

skips town and orders some cotton candy.

for rube-goldberg device operator

meeting Dostoevsky on the I-95

5 suspension cords from a large bass drum (still attached)

informationgrantedto happenperceptualinterfacedisregarded

wooden chair, always *fff*

Obligatory Introductory Phrase

for xylophone

merry-marie

for green frog squeaky dog toy

[=+

for various metals

True minimalism, that is, work conceived of singularized and essentialized performance is never actually achievable, since there are always complex systems of culture, language and phenomenology at work.

(breath)

Good for you for putting old heads on young shoulders!

(sword and shield)

SHOT HIMSELF DEAD

snaredrum

staring at a corner that turns to beige.

for woodblocks (5)

Bring me the head of Stewart Beach on a platter.

spoon, fork, knife

wear hats, switch gears, wear gears, switch hats, witch hears, swear gats

5 pitched wrenches and fedora

symmetry-is-boring

wineglass, mokubio, log drum, muted cowbell and taut rope

tweeting bird

(lg. metal bowl and sweaty palms)



74C14

for six beer bottles, hit with six brass mallets

The musical score consists of six staves, each representing a different bottle. The notation is as follows:

- bottle 1 (10% empty):** A single half note with a triplet bracket above it, indicating a triplet of eighth notes.
- bottle 2 (15% full):** A single half note with a triplet bracket above it, indicating a triplet of eighth notes.
- bottle 3 (40% empty):** A quarter note followed by a half note with a quintuplet bracket above it, indicating a quintuplet of eighth notes.
- bottle 2 (50% full):** A quarter note followed by a half note with a triplet bracket above it, indicating a triplet of eighth notes.
- bottle 2 (25% empty):** A quarter note followed by a half note with a triplet bracket above it, indicating a triplet of eighth notes.
- bottle 2 (10% full):** A quarter note followed by a half note with a septuplet bracket above it, indicating a septuplet of eighth notes.

Ah, yes

for mouth sounds

(tongue-taps) *pp*

"ss" *p*

"tuh" "ss" *f*

(squish-growlsounds) *ppp*

5:3 *mf*

(quick inhale with teeth) *mf*

"op" "ah" *f*

(blown air) *mf*

(closed-mouth fast air through nose) *f*

"ee" "aa" "oo" - "ii" *fff*

(like a pig squeal)

"tus" "tes" *pp*

(squishy) *mf*

(tongue-ram)

(inhaled low growl)

Anna, watching couple eating bagel together while he reads *The Speed of Trust* and she reads *The Sex Lives of Animals*

(bongo)
(low timbale)
(conga)
(triangle)
(cuiça)

♩ = 120

3 3 5 3 3

The image shows a musical score for a percussion piece. It consists of two staves. The top staff is a single melodic line with a key signature of one flat (Bb) and a common time signature (C). The bottom staff is a bass line with a 4/4 time signature. Above the top staff, five percussion instruments are listed vertically: (bongo), (low timbale), (conga), (triangle), and (cuiça). A tempo marking of ♩ = 120 is placed above the first measure of the bass line. The bass line features a series of rhythmic patterns, including triplets of eighth notes, a quintuplet of eighth notes, and other eighth-note patterns. The first measure of the bass line is marked with a '3' below it, indicating a triplet. The second measure is also marked with a '3'. The third measure is marked with a '5', indicating a quintuplet. The fourth and fifth measures are marked with '3's. The top staff begins with a half rest, followed by a series of eighth notes and quarter notes.

Arem

for a six pack of cheap beer

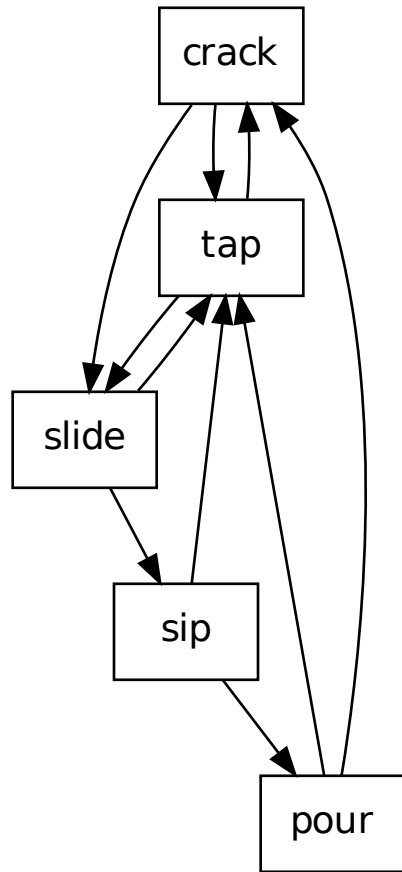

can list:

- 1) unopened
- 2) unopened
- 3) opened, full
- 4) unopened
- 5) opened, half-full/half-empty
- 6) opened, empty

start anywhere in the chain of actions.
perform the indicated action as quickly as possible on one of the six cans.
follow the arrows to another box.
repeat process for 5 seconds total.

bangs anecdote

for solo bongo player and one bongo

The musical score consists of two staves. The top staff is a vocal line with a tempo marking of quarter note = 96. It begins with a half note rest, followed by a quarter note with a dynamic marking of *p*. The melody then consists of five groups of eighth notes, each marked with a '3' above a bracket, indicating triplets. The bottom staff is a bongo line with 'x' marks representing hits. It features a series of rhythmic patterns corresponding to the vocal line, including a dotted quarter note, eighth notes, and various rests and accents.

a wo- man walks to a win- dow, sun- ny bangs.

(EXAMPLE OF BLURT)

MIKE-> NERD->[BLURT]->MIKE IS A NERD

for laptop operator

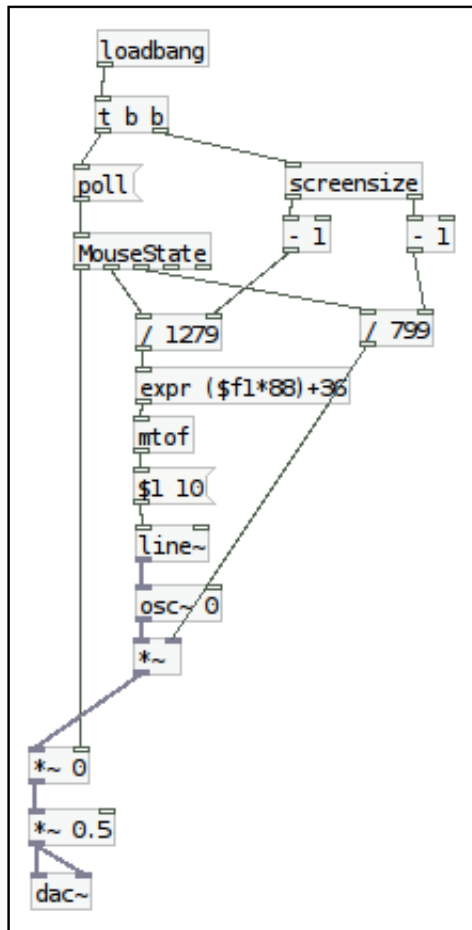

Before the concert:

1. Download PD-extended or compile it from source.
2. Re-create the patch on the left.
3. Maximize the patch window on the laptop computer you will performing from on the concert.
4. Leave edit mode (Ctrl+E)
4. Save the file.

At the concert:

0. Open the patch, compute audio. Hook up the computer's audio output to something audible to an audience.
1. Using the mouse, "sign" your name over the space of the entire screen.
(Pen down = left mouse button down, Pen up - left mouse button up)

example:

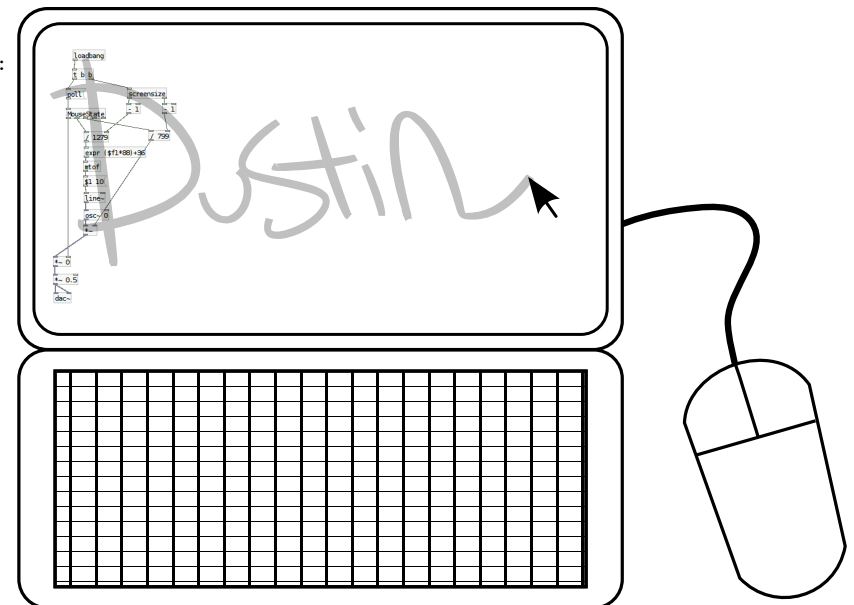

Crabbingoff Kingstreet

for wire-bound steel frame

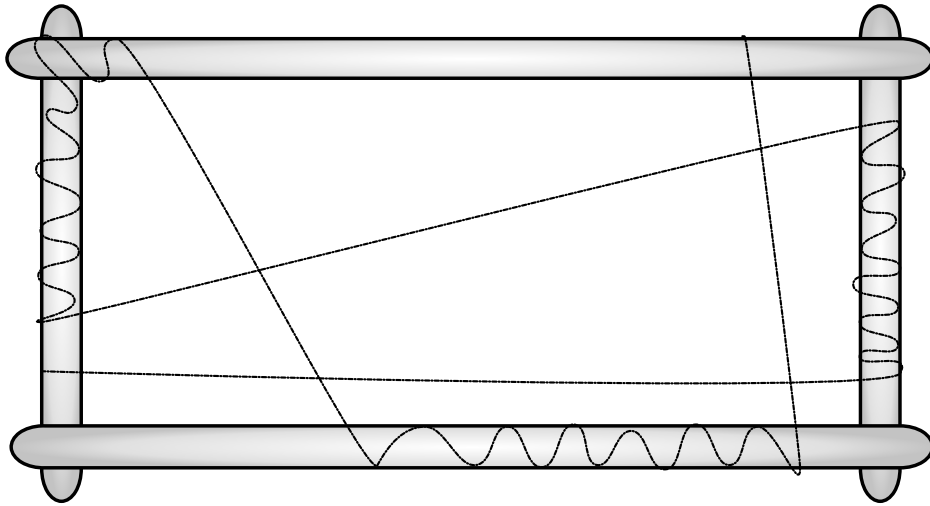

1 long steel string, wound around metal frame (4 exposed lengths).
Make sure to wind the string so it does not touch itself and each exposed length can resonate freely.

Play 5 consecutive boxes.
Row = String number.
Col = Time.
Put some sort of space or space signifier between each box.

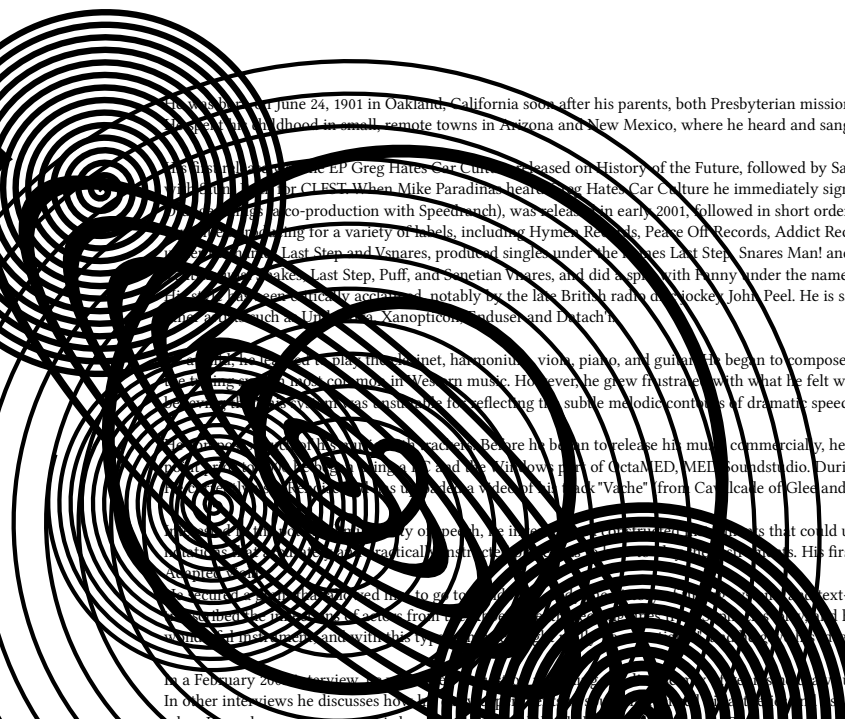
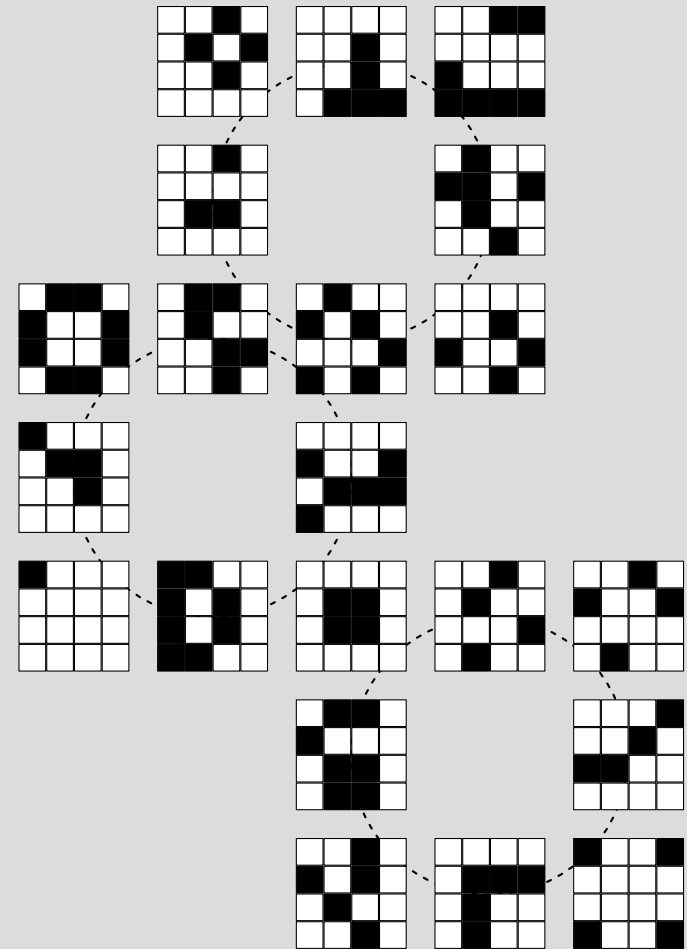

He was born on June 24, 1901 in Oakland, California soon after his parents, both Presbyterian missionaries, fled the Boxer Rebellion in China.

His childhood in small, remote towns in Arizona and New Mexico, where he heard and sang songs in Mandarin, Spanish, and American

music. His first LP Greg Hates Car Culture, released on History of the Future, followed by Salt on Zhark International and Fuck Canada

for CLEST. When Mike Paradinas heard Greg Hates Car Culture he immediately signed him for Planet Mu. The first LP on Planet

Mu (a co-production with Speedmach), was released in early 2001, followed in short order by five more releases, all before the end of

the year. He has since been working for a variety of labels, including Hymen Records, Peace Off Records, Addict Records, and Sublight Records. He has also pro

duced singles under the names Last Step and Vsnares, produced singles under the names Last Step, Snares Man! and Snares, appeared on compilations under

the names Last Step, Puff, and Sonetian Vsnares, and did a split with Punny under the name BeeSnares.

His work has been widely accepted, notably by the late British radio DJ, DJockey John Peel. He is said to have reinvented breakcore and set the

standard for it, such as Unimatic, Xanopticon, Induser, and Detach.

He plays the violin, the piano, the violin, the piano, and guitar. He began to compose at an early age, using the equal-tempered

system of tuning, common in Western music. However, he grew frustrated with what he felt were imperfections of the standard system of

tuning, and began to experiment with reflecting the subtle melodic contours of dramatic speech and, as a result, he burned all of his early

compositions. He began to release his music commercially, he worked primarily with OctaMED on an A

lbum, using a 24 and the Windows port of OctaMED, MED soundstudio. During 2003 and 2005 he also used Cubase in an

album. He has also released a video of his track "Vache" from Car Culture of Glee and Dadaist Happy Hardcore Pom Poms) play

ing. He has also released a video of his track "Vache" from Car Culture of Glee and Dadaist Happy Hardcore Pom Poms) play

ing. He has also released a video of his track "Vache" from Car Culture of Glee and Dadaist Happy Hardcore Pom Poms) play

ing. He has also released a video of his track "Vache" from Car Culture of Glee and Dadaist Happy Hardcore Pom Poms) play

ing. He has also released a video of his track "Vache" from Car Culture of Glee and Dadaist Happy Hardcore Pom Poms) play

ing. He has also released a video of his track "Vache" from Car Culture of Glee and Dadaist Happy Hardcore Pom Poms) play

ing. He has also released a video of his track "Vache" from Car Culture of Glee and Dadaist Happy Hardcore Pom Poms) play

ing. He has also released a video of his track "Vache" from Car Culture of Glee and Dadaist Happy Hardcore Pom Poms) play

ing. He has also released a video of his track "Vache" from Car Culture of Glee and Dadaist Happy Hardcore Pom Poms) play

ing. He has also released a video of his track "Vache" from Car Culture of Glee and Dadaist Happy Hardcore Pom Poms) play

ing. He has also released a video of his track "Vache" from Car Culture of Glee and Dadaist Happy Hardcore Pom Poms) play

ing. He has also released a video of his track "Vache" from Car Culture of Glee and Dadaist Happy Hardcore Pom Poms) play

ing. He has also released a video of his track "Vache" from Car Culture of Glee and Dadaist Happy Hardcore Pom Poms) play

He met the poet with the intention of performing this music on his Monophone while intoning "By the Rivers of Babylon". The poet responded enthusiastically, saying, "A play done entirely in this way, with this

music, is a blessing. His first such instrument was the Monophone, later

replaced by the Monophone. In Dublin, he met the poet with the intention of performing this music on his Monophone while intoning "By the Rivers of Babylon". The poet responded enthusiastically, saying, "A play done entirely in this way, with this

music, is a blessing. His first such instrument was the Monophone, later

replaced by the Monophone. In Dublin, he met the poet with the intention of performing this music on his Monophone while intoning "By the Rivers of Babylon". The poet responded enthusiastically, saying, "A play done entirely in this way, with this

music, is a blessing. His first such instrument was the Monophone, later

In a February 2005 interview, he discussed his approach to composition in his music, a property which the interviewer labelled "eclecticism". He replied: "I prefer to call it Surrealism."

In other interviews he discusses how he uses samples: "When I was a kid I'd use a bunch of ghetto blasters playing all at once to play different sounds I'd recorded with some other shitty ghetto blasters. A turning point was

while the dog meat's cookin'

for a hungry knife-wielding person, 3 red potatoes and a stalk of celery

A musical score on a single staff with a 5/4 time signature. The tempo is marked as ♩ = 60. The score consists of several measures of music with various annotations:

- At the beginning, there is a measure with a whole note on the first line (F5) and a cross symbol (X) above it. Below this measure is the instruction "SWIRL KNIFE AROUND".
- The next measure contains three quarter notes on the first line (F5, G5, A5). Above these notes is a bracket with the number "3" and the instruction "SLICE EACH POTATO IN HALF".
- The following measure contains five eighth notes on the first line (F5, G5, A5, B5, C6). Above these notes is a bracket with the number "5" and the instruction "CHOP CELERY STALK".
- The final measure contains a whole note on the first line (F5) and a cross symbol (X) above it. Below this measure is the instruction "CRUNCH SOMETHING BETWEEN YOUR TEETH".

The score ends with a double bar line. To the right of the double bar line, the text "YOU MAY EAT NOW" is written.

The image shows a musical score for a heterogeneous pitched instrument, consisting of three staves. The tempo is marked as $\text{♩} = 96$. The first staff is in treble clef and contains four measures with dynamic markings *p*, *fff*, and *ppp*. It features triplets and a quintuplet. The second staff is in treble clef with a key signature of one flat and contains four measures with dynamic markings *ppp*, *f*, and *p*. It includes a quintuplet and a triplet. The third staff is in treble clef and contains four measures with dynamic markings *pp*, *ff*, and *p*. It features a quintuplet. The score concludes with double bar lines on each staff.

for a heterogeneous pitched instrument
Gazebo, Gazelle, zilch.

Jew-Goldberg, the accountant, skips town and orders some cotton candy. for rube-goldberg device operator

KEY:

1 = operator picks up golf club, swings it at the first book and begins the sequence.

2 = 5 books of scores (dominos): Buxtehude Organ Works , Bach Mass in B Minor, Beethoven Symphony No. 3, Berlioz Requiem and Brahms Hungarian Dances

3 = music stand used as pulley, (books are tied to each other and strung over the stand) book on left is suspended in air (Berio Sequenza for Piano), book on right is on ground (Boulez Structures)

4 = plank of wood on a can of mushroom soup, tied to 5's dollar bill

5 = toy race car with mechanical wheels (pull-back to make car move), car wheels are wound back and the car is held in place with a dollar bill.

6 = a large triangle, the car must fly through the triangle and ting it on its exit sequence (but still must completely go through it).

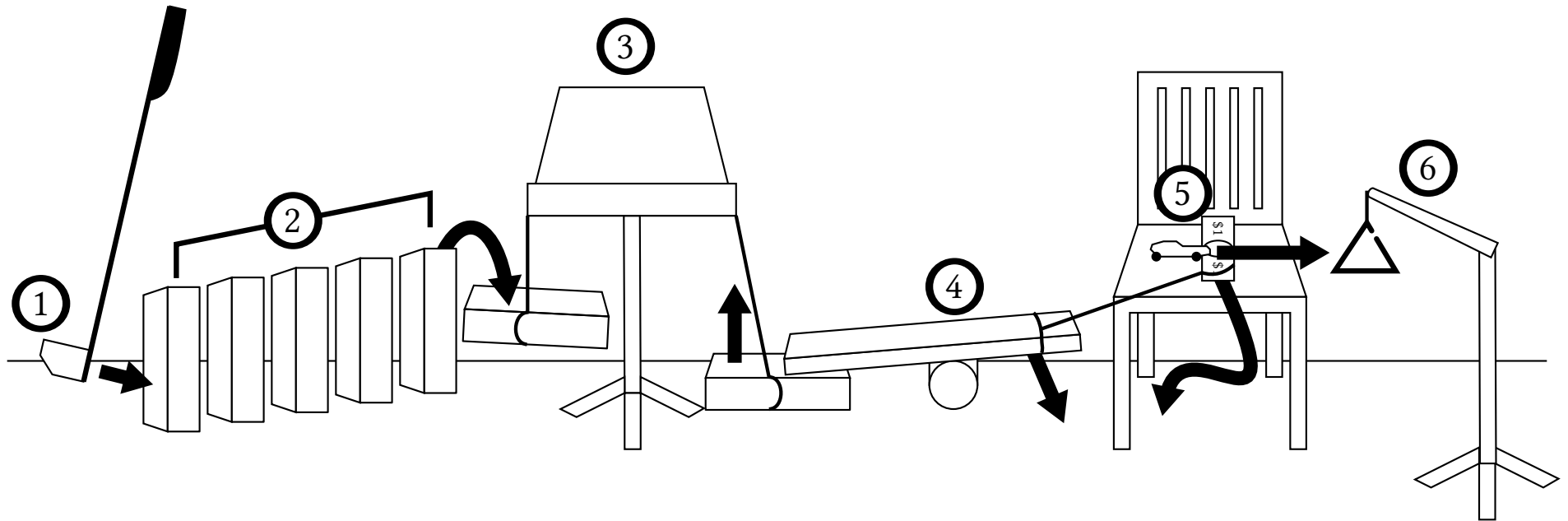

5 suspension cords from a large bass drum (still attached)

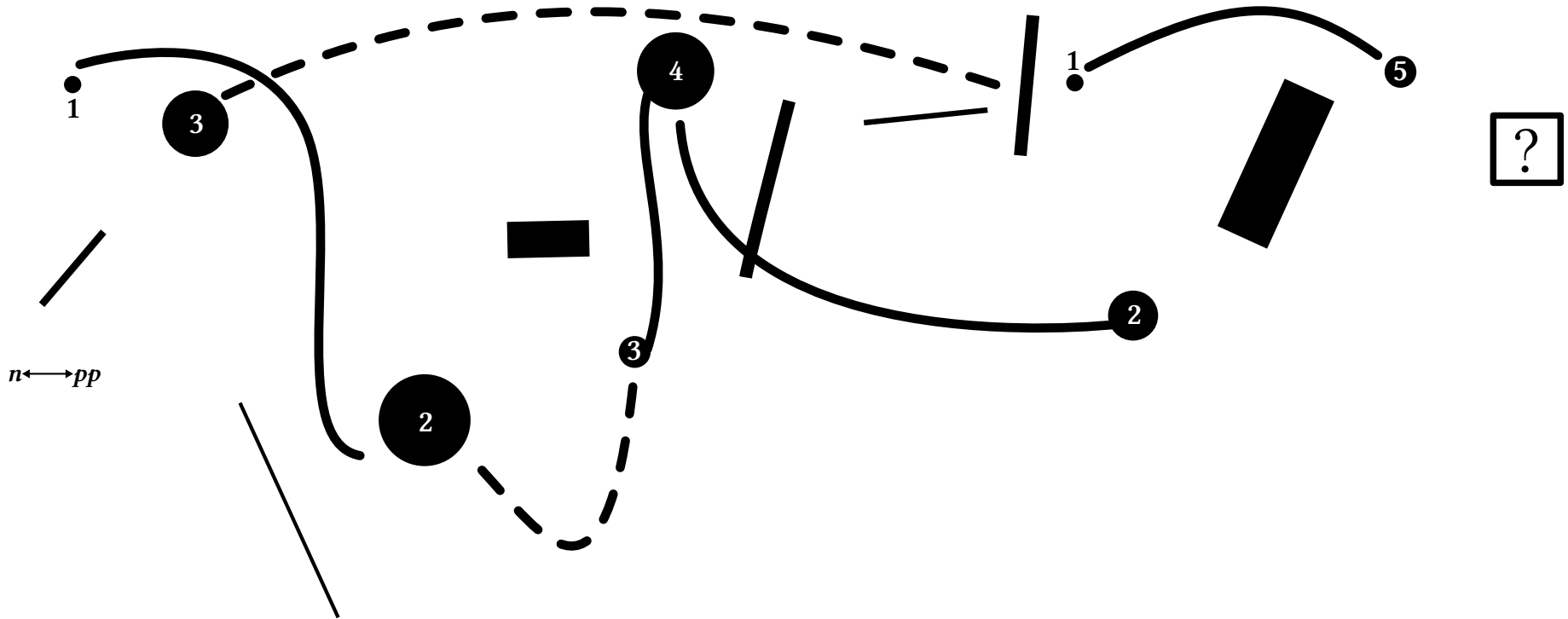

meeting Dostoevsky on the I-95

information granted to happen perceptual interface disregarded

The image shows a musical score for a wooden chair performance. It consists of three staves. The top staff has a 7:5 ratio annotation above it and a 3-measure triplet annotation. The middle staff has a 5-measure annotation, a 7-measure annotation, and a 5:6 ratio annotation. The bottom staff has a 3-measure triplet annotation. The text 'wooden chair always *fff*' is written to the left of the staves. The score includes various musical notations such as notes, rests, and slurs.

perform one staff, accompanied by playback of a precording of the other 2 staves
the volume of the recording should match the sound of the live chair

Obligatory Introductory Phrase

for xylophone

5" total

hum along as you play

choose a path

The score consists of a single melodic line in treble clef with a common time signature. The melody is composed of eighth notes and quarter notes, featuring several triplet markings. The dynamics are marked as *p* (piano) and *mf* (mezzo-forte). The score is divided into three sections by large curved lines labeled "choose a path". The first section starts with the instruction "hum along as you play". The second section branches into three paths. The third section branches into six paths. Each path contains the same melodic line with dynamic markings. The total length of the piece is indicated as 5 inches.

merry-marie

for green frog squeaky dog toy

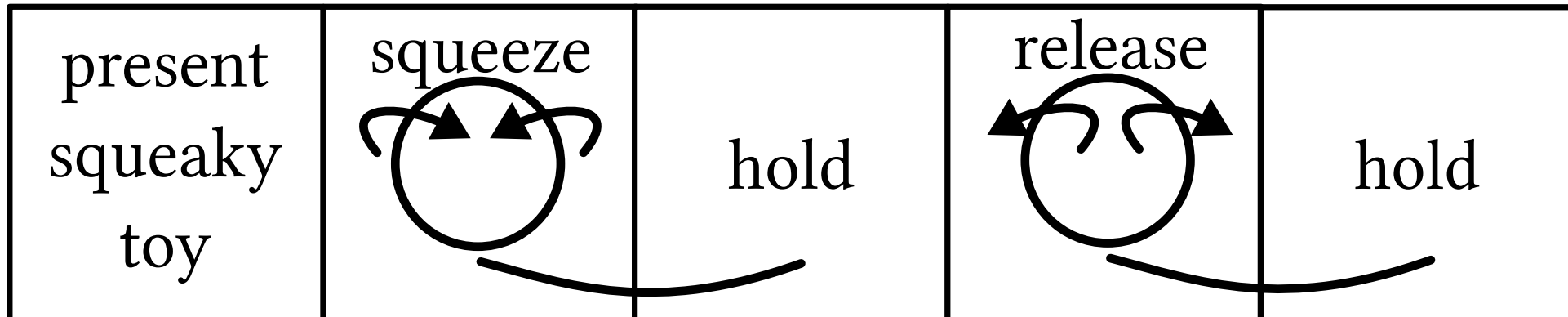

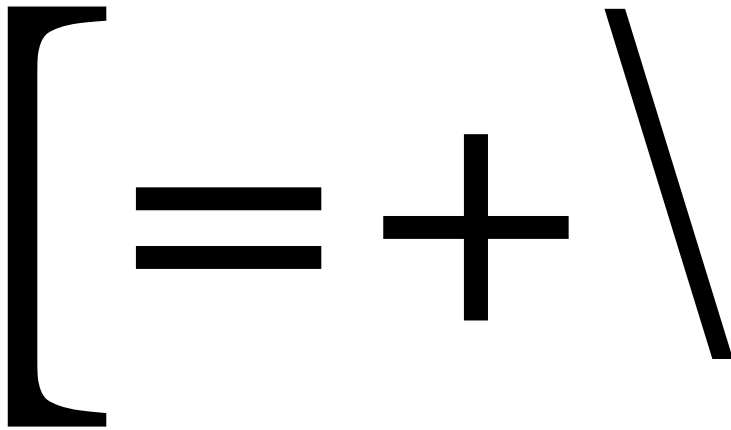

for various metals

$\text{♩} = 72$

(complex metal) (4 almglocken)

BOWED HARD MALLETS

SOFT MALLET

p *f* *ff* *mp*

slowly rise out of water

A musical score for percussion on a single staff. It begins with a tempo marking of quarter note = 72. The first measure is a single note marked *p* (piano) with the instruction "(complex metal) BOWED". A crescendo hairpin leads to a second measure marked *f* (forte). A third measure is marked *ff* (fortissimo) and contains a quintuplet of notes. A fourth measure contains a triplet of notes. The final measure is marked *mp* (mezzo-piano) and contains a single note with the instruction "(suspended nipple gong, halfway submerged in water) SOFT MALLET". An arrow points from this note to the text "slowly rise out of water".

True minimalism, that is, work conceived of singularized and essentialized performance is never actually achievable, since there are always complex systems of culture, language and phenomenology at work.

♩ = 60

upbow = breath in
downbow = breath out

make no additional movements or sounds

Good for you for putting old heads on young shoulders!

instructions:

weild a sword (empty glass soda bottle) and a shield (a flexible "NO TRESSPASSING" or "BEWARE OF DOG" sign) in your left and right hands respectively.

pick any square to begin in. from this start point, plan a path through the grid that passes through each square exactly one time.

for each square, play the indicated passage and then immediately move to the next square.

curved lines with arrows indicate to swing your sword left or right.
the arrowed line with a bend indicates to blow gently over the bottle's top.
curved lines with no arrows indicate to bend/shake the shield.
the number of bends indicates how many times to bend/shake the sheild.

all actions should be forceful and fast
yet produce very quiet, gentle sounds.

each square should last slightly over half a second.
total duration: 5 seconds.

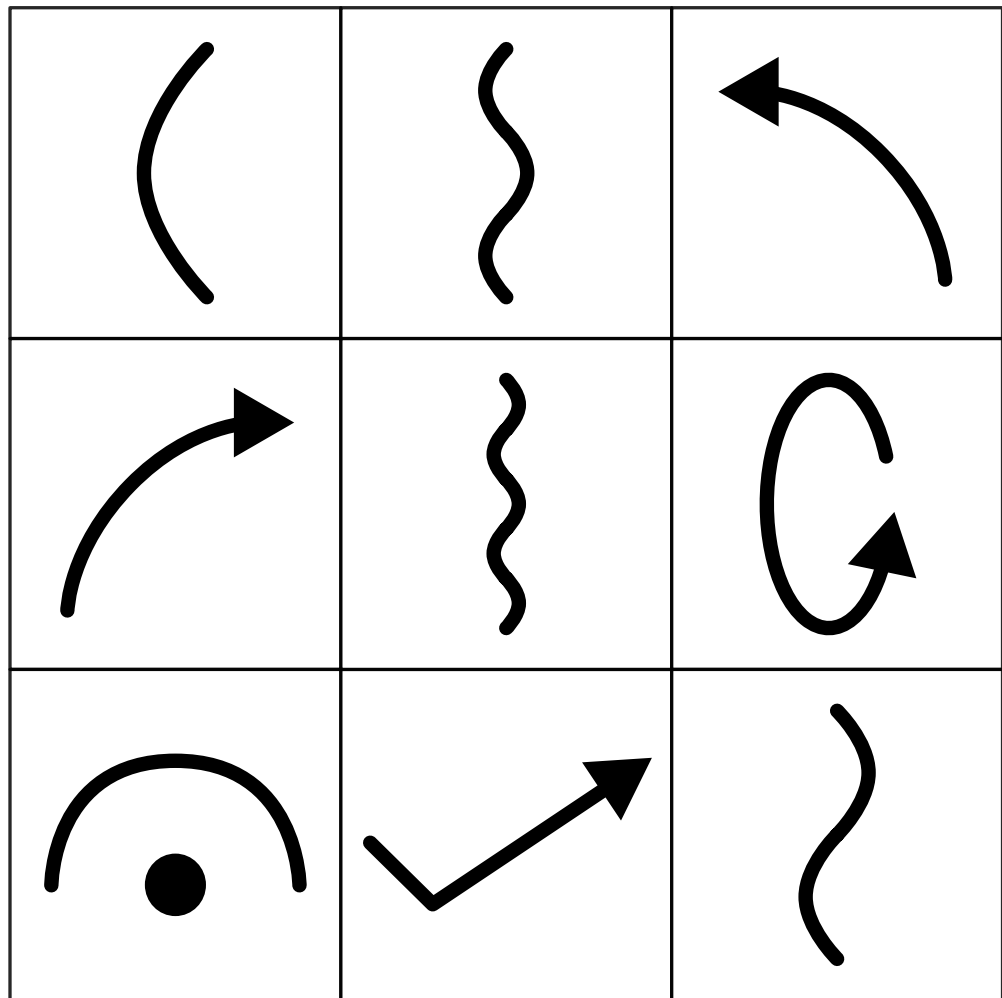

SHOT HIMSELF DEAD

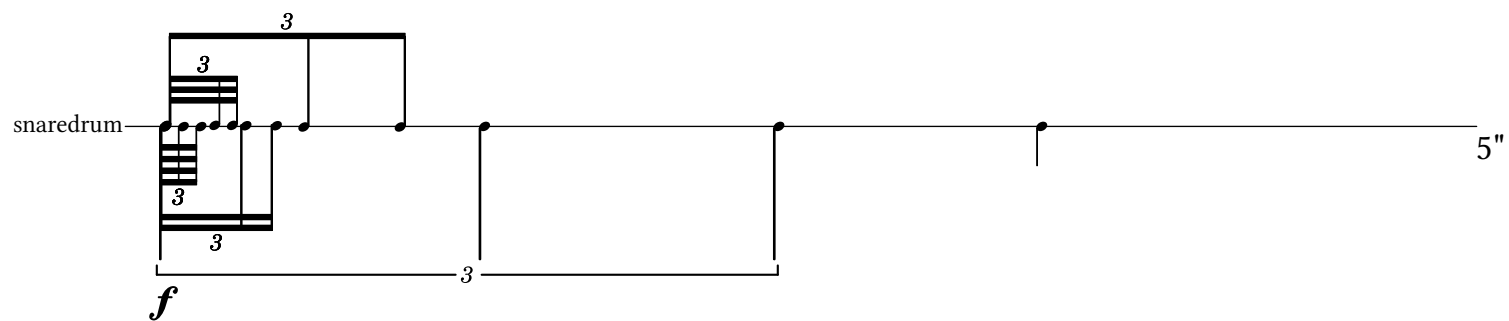

staring at a corner
that turns to beige.

for woodblocks (5)

♩. = 48

THREADED METAL ROD
FELT MALLET

ppp *ppp*

The musical notation consists of two staves. The top staff is labeled 'THREADED METAL ROD' and the bottom staff is labeled 'FELT MALLET'. The time signature is 12/8. The tempo is indicated as ♩. = 48. The music is written in treble clef. The melody starts with a quarter note on G4, followed by a quarter note on A4, a quarter note on B4, and a quarter note on C5. The bottom staff has a whole rest for the first two measures, followed by a quarter note on G3, a quarter note on A3, a quarter note on B3, and a quarter note on C4. The dynamics are marked *ppp* at the beginning and end of the piece, with a hairpin indicating a slight increase in volume.

Bring me
the head
of Stewart
Beach on
a platter.

♩ = 156

spoon

fork

knife

instructions:

scrape a large trash can lid with indicated utensils.
the sound should be piercing and unstable throughout.

wear hats,
switch gears,
wear gears,
switch hats, witch hears, swear gats

5 pitched wrenches

$\text{♩} = 60$

1 2 3 4 5 1 2 3 5 4 2 1 5 3 4 2 5 1 4 3 5 2 4 1 3

instructions:

before piece begins, don a fedora.

notehead size indicates relative loudness

number above note indicates type of mallet to use (1 = cloth, 2 = yarn, 3 = rubber, 4 = wood, 5 = metal)

symmetry-is-boring

5 seconds (2in = 1sec)

The musical score consists of four staves. The first staff, labeled 'wineglass', has a single note on the first line with a dynamic marking of *f*. The second and third staves, labeled 'mokubio and lg. log drum', each have a series of 15 notes on the first line, with a dynamic marking of *f*. The fourth and fifth staves, labeled 'muted cowbell', each have a series of 15 notes on the first line, with a dynamic marking of *f*. The sixth staff, labeled 'taut rope', has a single note on the first line with a dynamic marking of *f*. A double bar line is at the end of the sixth staff. A horizontal arrow above the staves indicates a duration of 5 seconds, with a note that 2 inches equals 1 second.

Instructions:

- Shatter the wineglass in one strike, drop or break with metal rod.
- For muted cowbell lines, play both staves on a single muted cowbell, medium mallets.
- For mokubio / log drum lines, play both staves simultaneously on a single mokubio and a single log drum, hard mallets.
- Pluck the taut rope, it should be very long (>10 ft.) and made of a fibrous material, producing a low but still audible pitch.

tweeting bird

